

Sequence of Operation

When the occupancy sensor(s) in the room senses movement, lights will do nothing. The switch on the wall can be used to turn the lights on or off regardless of the state of the occupancy sensor(s). A quick press up or down of the switch will turn the lights on or off. A press and hold up or down will dim the lights up or down. Activating the Quiet Time preset will ignore the occupancy sensor(s) for up to 2 hours. Activating the AV Mode preset will turn off the whiteboard lights and dim the overhead lights to 50%. The daylight sensor(s) will determine the level of artificial and natural light in the daylight zone(s) and dim the lights to maintain a predetermined set point. The lowest dimming value between the daylight sensor and wall switch will be the dim level used. When the room becomes vacant, the lights will turn off after a predetermined amount of time (Default 15 minutes). When a Demand Response event is triggered the lights will dim down to a predetermined level.

- SPECIFICATION:**
1. LIGHTING CONTROL SYSTEM TO BE MANUFACTURED BY ECHOFLEX SOLUTIONS INC.
 2. ECHOFLEX LIGHTING CONTROL SYSTEM SHALL HAVE THE ABILITY TO BE FACTORY PRE-LINKED AND PRE-CONFIGURED OR PROGRAMMED ON SITE USING SIMPLE TAP, SMART CLICK OR GARIBALDI SOFTWARE.
 3. CONTROLLERS SHALL BE ABLE TO FUNCTION AS A STAND ALONE SYSTEM ALONG WITH THEIR OPTIONAL PERIPHERAL WIRELESS DEVICES INCLUDING A WALL SWITCH, SPLIT CONTROLLED RECEPTACLE, AND OCCUPANCY SENSOR.
 4. CONTROLLERS SHALL BE ABLE TO BE NETWORKED TOGETHER TO FORM AN INTEGRATED BUILDING SOLUTION.
 5. ECHOFLEX ELED1H: 0-10V DIMMING CONTROLLER SHALL BE ETL RECOGNIZED AND UL LISTED, CONFORMING TO UL60730, AND CERTIFIED TO CAN/CSA STANDARD E60730 AND UL924. ALL SYSTEM CONTROL ELECTRONICS SHALL STORE PROGRAMMING IN NON-VOLATILE MEMORY. THE CONTROLLER SHALL BE CAPABLE OF REPEATING SIGNALS AND TRANSMITTING STATUS.
 6. OCCUPANCY SENSORS (OS): OCCUPANCY SENSOR SHALL BE SOLAR POWERED WIRELESS SENSOR WITH AN OPTIONAL BATTERY. SENSOR SHALL BE COMPATIBLE WITH OCCUPANCY AND VACANCY MODES WHEN USED IN CONJUNCTION WITH THE DIMMING ROOM CONTROLLER. SENSOR SHALL PROVIDE LED INDICATION FOR RF RANGE CONFIRMATION. SENSOR SHALL WIRELESSLY COMMUNICATE WITH THE SPLIT CONTROLLED RECEPTACLE. SENSOR SHALL HAVE ABILITY TO FUNCTION UP TO 9 DAYS (MOS-IR) OR 7 DAYS (MOS-DT) IN COMPLETE DARKNESS.
 7. PHOTO SENSORS (PS): PHOTO SENSOR SHALL BE SOLAR POWERED WIRELESS SENSOR WITH AN OPTIONAL BATTERY. SENSOR SHALL BE COMPATIBLE WITH OPEN AND CLOSED LOOP MODES WHEN USED IN CONJUNCTION WITH THE DIMMING CONTROLLER. SENSOR SHALL PROVIDE LED INDICATION FOR RF RANGE. LIGHT SENSOR SHALL BE CAPABLE OF READING LUX LEVELS BETWEEN 0 & 65,500.
 8. RF SYSTEM SHALL NETWORK WIRELESSLY. INTEGRATION WITH BMS/DEMAND RESPONSE VIA THE USE OF GATEWAYS AND WIRELESS/WIRED I/O INTERFACES. VERIFY AND INSTALL ONLY THOSE INTERFACES INDICATED ON THE PLANS.
 9. EC SHALL INSTALL ECHOFLEX SYSTEM AS INDICATED PER MANUFACTURER'S FINAL DRAWINGS AND INSTALLATION DOCUMENTS IN ACCORDANCE TO ALL LOCAL AND NATIONAL CODES. FACTORY ONSITE START UP AND TRAINING IS OPTIONAL. ECHOFLEX REQUIRES 3 WEEKS ADVANCED NOTICE TO SCHEDULE ONSITE START UP IF REQUESTED. ECHOFLEX WILL PROVIDE SYSTEM VERIFICATION AND ADJUST PROGRAMMING IF REQUIRED TO CUSTOMER REQUIREMENTS.
 10. THIS DRAWING REPRESENTS DESIGN CONCEPT AND INTENT ONLY. WE DO NOT GUARANTEE THE INFORMATION IN THIS DOCUMENT IS SUITABLE FOR YOUR PARTICULAR APPLICATION, NOR DO WE ASSUME ANY RESPONSIBILITY FOR YOUR SYSTEM DESIGN, INSTALLATION OR OPERATION. WE RESERVE THE RIGHT TO MAKE CHANGES TO THE PRODUCTS DESCRIBED OR INFORMATION HEREIN AT ANY TIME WITHOUT NOTICE AND WITHOUT ANY OBLIGATION.
 11. SPECIFICATIONS SUBJECT TO CHANGE WITHOUT NOTICE.
 12. TELEPHONE FACTORY SUPPORT SHALL BE AVAILABLE AT NO ADDITIONAL COST TO THE EC OR OWNER.

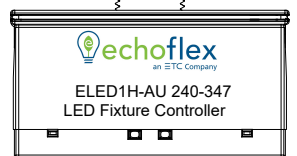
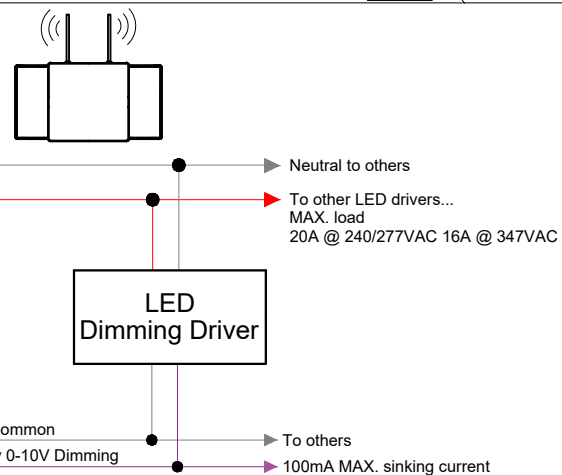

Typical Material List		
Qty	Part #	Description
4	ELED1H-AU	LED Dimming Controller 240-347V
1	MOS-DTUB	Occupancy/Vacancy Sensor (1900 Sq. Ft.)
1	TAP-31U	Daylight Sensor
6	PTM365UW	Decorator Style Switch
1	GW2-U	ADR/BACnet Interface

Title 24 Compliance			
Section	Requirement	Device	Part #
130.1a/b	Local Switching Multi-Level Dimming		PTM365UW
130.1c	Fully Automatic Light shut Off		MOS-DTUB
130.1d	Multi-Level Daylight Control		TAP-31U
130.1e	Demand Response Ready		GW2-U

Typical Classroom w/Daylight Harvesting

Echoflex Solutions, Inc.
 38924 Queens Way Unit #1
 Squamish, British Columbia
 Canada V8B 0K9
 Phone: 1 (778) 733-0111
 Toll Free: 1 (888) 324-6359
 Fax: 1 (604) 815-0078
 echoflexsolutions.com

an ETC Company

UNLESS OTHERWISE SPECIFIED - ALL DIMENSIONS IN MILLIMETERS - #9DC-9642